

**A CASE STUDY
SLOPE INSTABILITIES / REMEDIAL MEASURES
FOR A VIADUCT FOUNDATIONS**

Prof.Dr.Turan Durgunoğlu(1) ,Dr.Andrew Lord(2) ,H.Fatih Kulaç(3)

(1) Professor, Boğaziçi University, Civil Eng. Department, İstanbul
(2) OVE ARUP & Partners, ARUP Geotechnics, London, England
(3) ZETAŞ Earth Technology Corp., Geotechnical Consultancy and Design, İstanbul, Turkey

ABSTRACT

Viaduct V5 (presently named as Mustafa İnan Viaduct) constructed by the Contractor Impregilo, Sezai Türkeş - Fevzi Akkaya Joint Venture (IGL-STFA JV) within the scope of Kınalı - Sakarya Motorway Project in Turkey. The pier 8R of the viaduct experienced lateral and vertical movements twice, first in June 1988 and second in August 1990. An extensive subsoil investigation, surface geology, monitoring, analysis and evaluation campaign performed between 1988 and 1990 to provide the stability of the eastern slope of the valley where pier 8R is located. The additional subsoil investigations indicated that the limestone covering the eastern slope on which the piers were located by shallow foundations in the original design is not stable bedrock but slope debris composed of limestone boulders above mudstone bedrock. The instabilities took place along the limestone debris / mudstone interface leading to movement of pier 8R. The other piers not constructed until the movement of pier 8R were also reevaluated and whole foundation design were reassessed.

1. INTRODUCTION

Viaduct V5 (presently named as Mustafa İnan Viaduct) constructed by the Contractor Impregilo, Sezai Türkeş - Fevzi Akkaya Joint Venture (IGL-STFA JV) within the scope of Kınalı - Sakarya Motorway Project in Turkey. The viaduct consists of two abutments and nine piers along each carriageway. After the construction of three piers located at the eastern slope of Ağadere valley, before launching of the viaduct decks, lateral and vertical movement of pier 8R were recorded. Figure 1 presents the design position and position according to the measurements of 03.06.89 after first movement took place. A lateral movement of 187 - 207mm in the X direction (towards valley bottom) and that of 131 - 146mm in the Y direction (parallel to valley bottom) took place. Since the lateral movements were rather significant, it was compulsory to determine the possible causes of the movements to develop the remedial design measures in order to secure the stability of

FIGURE 1 - MOVEMENT MEASUREMENTS FOR PIER 8R

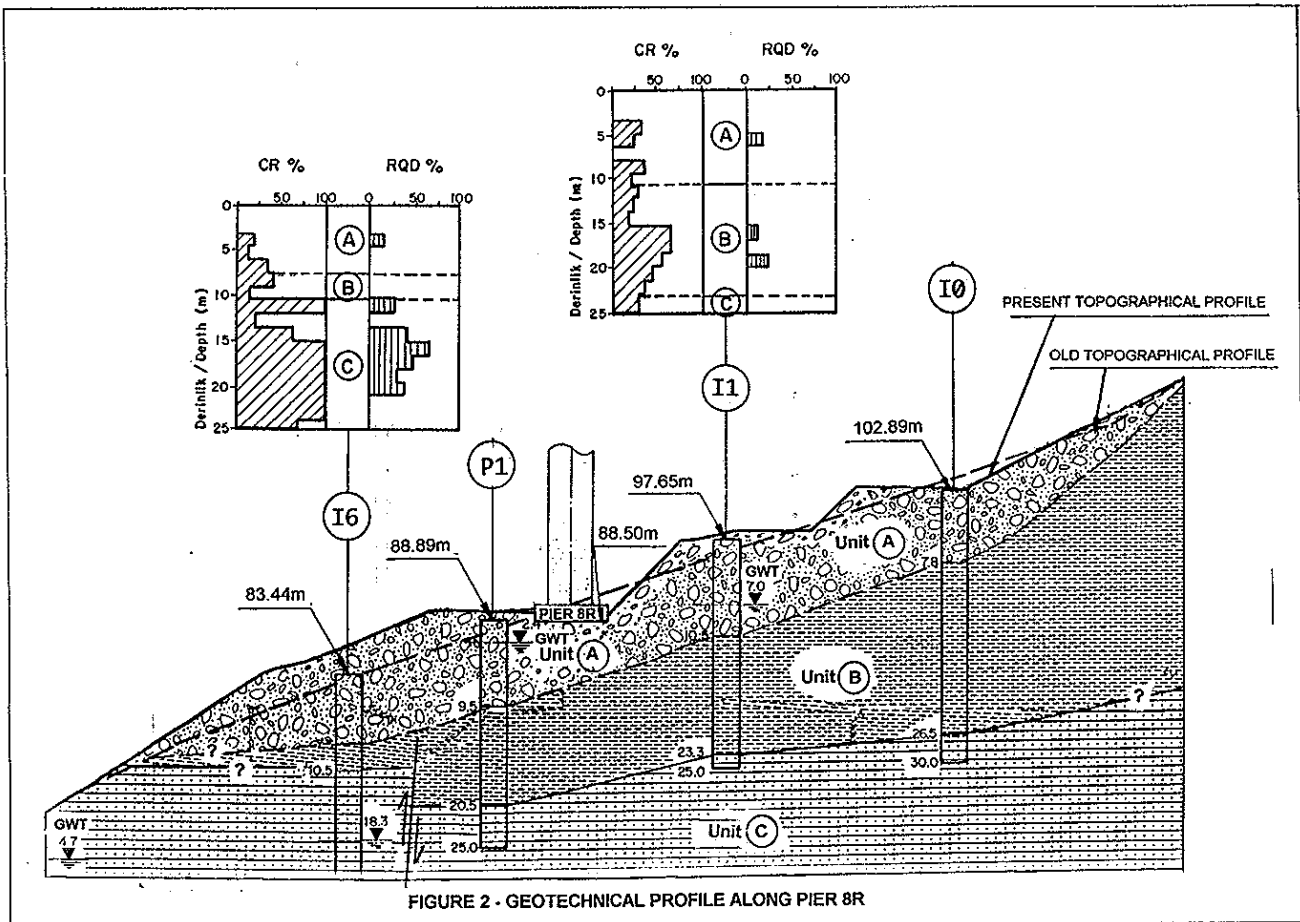
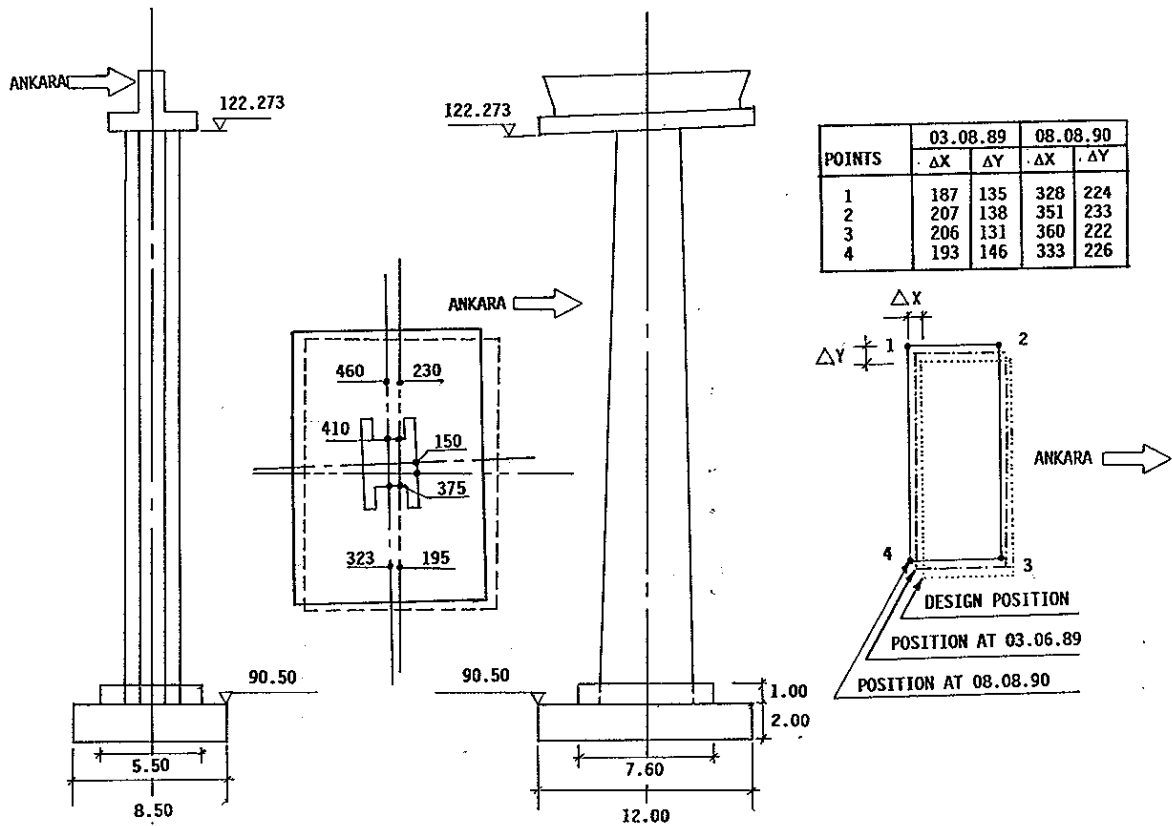

FIGURE 2 - GEOTECHNICAL PROFILE ALONG PIER 8R

the pier 8R foundation. In addition, it was decided to reassess the other pier foundations considering the stability problem observed in pier 8R. For this purpose, a wide geotechnical investigation campaign started to identify the subsoil conditions at pier locations at the eastern slope of Ağadere valley. With the case, authors are involved during the reassessment stage. The geotechnical survey performed between August 1988 and November 1988 and the final recommendation report / remedial design drawings prepared in December 1988. The remedial design recommended supporting of shallow foundations of already constructed piers by means of micro piles and pile foundations for other piers. In addition some regrading and drainage is recommended to increase the stability of the eastern slope of Ağadere valley. However, during implementation of remedial design, a crack was observed above pier 8R and position of this pier is checked again on 08.08.1990. It was determined that this time the pier moved 140 - 154 mm in the X direction (towards valley bottom) and that of 80 - 95mm in the Y direction (parallel to valley bottom) as illustrated in Figure 1. This second movement occurred during regrading of the slope is determined to be due to not following the construction scheme imposed by the remedial design. This movement destructed the micropiles installed through the shallow foundation according the the remedial design of 1988. Therefore this time, four large diameter deep shaft foundations at four corners of the pier foundation are recommended to increase the local stability of the pier 8R. As summarized in this introduction, a very major viaduct pier experienced two times significant amount of lateral movements first due to the misinterpretation of the subsoil data and selection of improper foundation type, second due to the wrong construction sequence.

2. SUBSOIL CONDITIONS

Figure 2 presents the geotechnical profile along pier 8R in the direction of the resultant movement vector of the first movement. The pier 8R is located onto slope desbris (unit A) composed of limestone boulders within clayey matrix. Unit B easily differentiated during borings and also with increase in core recovery (CR) , RQD values is bedrock mudstone. Unit C is siltstone forming the valley bottom. The brief summary of these units is given below;

Unit A - Slope Debris

Clayey or crystallized limestone boulders mixed with clayey fine grained matrix, brown-beige and occasionally grey colored, in a loose form. The thickness vary between 0.0 to 15.65m with an average of 6.60m. Clayey matrix is classified as CL according to USCS. Core recovery (CR) varies between 10 to 100 % and rock quality designation (RQD) is 0 to 80 percent meaning very poor rock quality.

Unit B - Mudstone

Claystone - siltstone of grey colored, in zone of extensive weathering brown colored clay zones of low plasticity (CL) very thinly bedded and extensively fissured. The thickness varies between 0.0 to 15.40m, CR is 0 to 100 percent and rock quality designation, RQD is 0 to 68 percent meaning very poor rock quality.

Unit C - Siltstone

Siltstone, claystone and fine sandstone with clay interlayers (zones of weakness), burgundy colored thinly bedded. The starting depth is 0.0 to 31.0m, CR is 5 to 100 percent and RQD is 0 to 90 percent meaning very poor to poor rock quality.

3. STABILITY ANALYSIS by BACK-CALCULATION SCHEME

Back-calculation scheme developed by Nguyen(1984) is used in the analysis. Analysis are carried out to determine the combination of the friction angle values ϕ_r , pore water pressure ratios (ru) and the external effects such as the load coming from the pier and that may occur during an earthquake (k : lateral earthquake coefficient) that leads to a condition of limit equilibrium (factor of safety FS = 1.00).

The analysis for the loaded case (only the pier constructed) is presented in Figure 3. It is seen that for a possible range of values of pore water pressure ratio, $ru = 0.10$ to 0.20 , the required friction angle value for the analyzed slide surface under static conditions is $\phi_r = 23.7 - 26.6$ degrees. According to laboratory results, clay zones within the debris and mudstone resulted an average plasticity index value of $I_p = 15$. For this value, based on empirical relations developed by Kenney(1967), the residual friction angle is about $\phi_r = 24.0$ degrees.

As a result, an interface friction angle value of $\phi_r = 24.0$ is selected for use in the remedial design.

4. REMEDIAL MEASURES and DESIGN CONSIDERATIONS

It is shown by the stability analysis that, increase in pore water pressure due to heavy rains with poor surface and subsurface drainage conditions and due to pier loading especially during minor earthquakes led to the instability of pier 8R and would cause the instability of other piers if the original design were not reassessed after the movement of pier 8R. For this purpose, a remedial design is developed mainly with below considerations;

FIGURE 3 - Back Calculation Analysis for the topography of June 1988

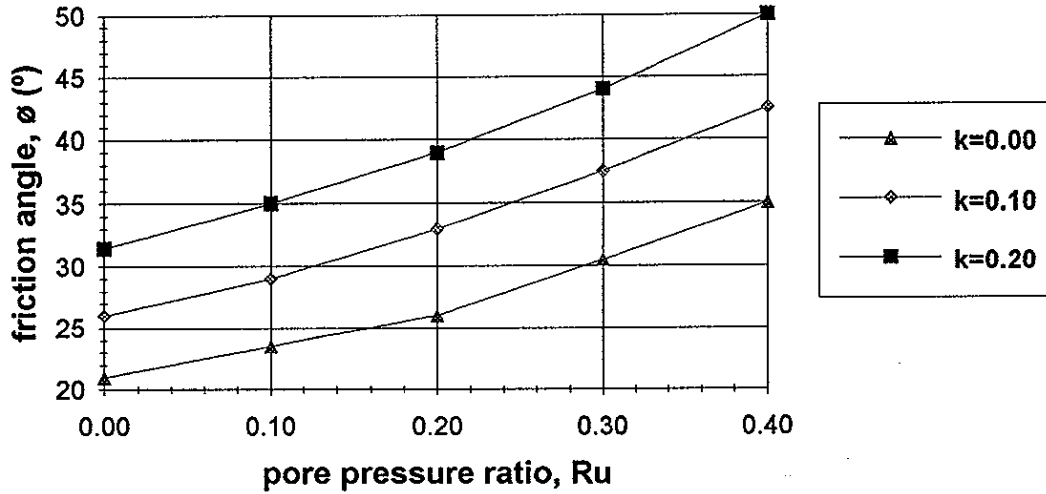
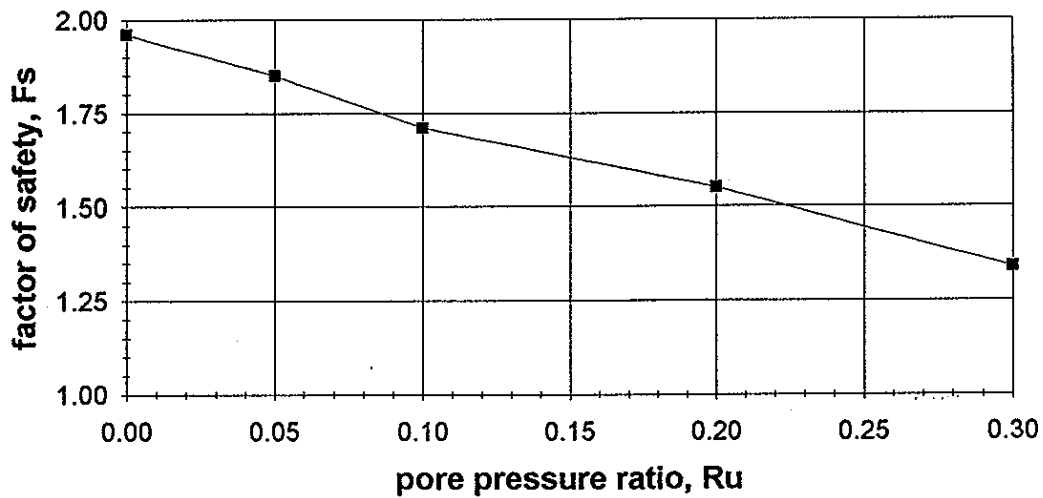

FIGURE 4 - Factor of safety under static conditions after remedial measure implementation ($k=0.00$, $\phi=24^\circ$)



- * reduce gravity loads by means of regrading.
- * keep pore water pressures low by means of surface French drains and subsurface subhorizontal drains.
- * Eliminate external pier loading on the slope, by means of underpinning the constructed shallow foundation by micropiles.
- * Revise the design of not constructed piers and implement deep foundations by either large-diameter piles or micropiles considering the constructibility.
- * Following a strict construction scheme in order not to lead any instability during implementation of above recommendations.

Figure 4 presents the achieved factor of safety values against instability after the above remedial design measures implemented. A factor of safety of $FS = 1.85$ under static conditions and $FS = 1.01$ under a lateral earthquake coefficient of $k = 0.2$ is satisfied with the proposed remedial design considering that the pore water pressure ratio will be reduced to $ru = 0.05$ by proposed drainage system.

5. SECOND MOVEMENT OF PIER 8R in August 1990

During the installation of drainage pipes for subhorizontal drains, a persistent crack was observed to develop above pier 8R in August 1990. The reason of this second movement is easily identified as not following the construction sequence given in the remedial design. In the remedial design report, it was stated that the regrading above pier 8R should be done the first and the regrading below pier 8R should be done the last. However, since both regrading activities started simultaneously, the local stability around pier 8R is not satisfied. Since micropiles have negligible lateral capacity, they could not contribute to the slope stability and a second major movement occurred in pier 8R, this time the viaduct deck was launched and the motorway was about to be started operation. Following measures were recommended;

- * excavate the top of the pier 8R to reduce the driving force
- * keep pore water pressures low by means of additional surface French drains and subsurface subhorizontal drains.
- * Install no.40 micropiles as a short-term measure to carry the superstructural loads considering that the micropiles installed according to the first remedial design is bent due to significant lateral movement of the pier.
- * Construct four large diameter manually excavated shafts each 3.60m in diameter at the four corners of the pier foundation in order to carry the superstructural loads and

also to increase the stability condition at the subject area. The shafts are constructed by peripheral supporting with root piles of 11cm diameter. One shaft is constructed at one time (at no time two shafts are constructed simultaneously). The shafts are socketed to lower siltstone.

A continuous record of lateral and vertical movements were taken during this second stage remedial works around pier 8R. The factor of safety with this additional measures is increased to $FS = 1.56$ under design criteria of $k = 0.20$ earthquake and $ru = 0.05$ pore water pressure ratio.

6. CONCLUSIONS

This paper presents a case study on the instability problems experienced with the foundations of Viaduct V5 in Kınalı - Sakarya Motorway in Turkey. The subsoil conditions, the movement records, the analysis and remedial designs performed for this viaduct between 1988 and 1990 are summarized. Two main conclusions may be obtained from this case study;

- * A wrong interpretation of subsoil investigations may lead to a wrong selection of foundation types. In this case, limestone boulders were evaluated as limestone bedrock and as a result shallow foundations were proposed under all piers in the original design. However, reevaluation of the available soil data and additional subsoil investigations indicated that the limestone boulders are debris material within clayey matrix. The interface between the top debris and bottom mudstone is a potential instability surface as experienced in pier 8R. Implementation of superstructural loads onto debris by shallow foundations results in instabilities therefore already constructed footings are supported by micropiles to carry the vertical loads and deep foundations are recommended and implemented for other not constructed piers with a design revision.
- * Construction sequence is very significant. In this case, not following the construction sequence imposed in the remedial design led to a second movement of pier 8R this time more critical due to the presence of viaduct deck on top of the pier. At this point, the significance of construction supervision by the Designer and a good monitoring network should be mentioned as well.

7. ACKNOWLEDGMENT

We would like to give our sincere thanks to General Highway Directory Research Department and First Division for their technical support and Contractor Impregilo, Sezai Türkes - Fevzi Akkaya Joint Venture (IGL-STFA JV) for their continuous cooperations through the design activities.

REFERENCES

Durgunoğlu, Turan, (1988), "Kınalı - Sakarya Motorway - Lot 4A Ağadere Viaduct - V5 Geotechnical Report for the Stability and Foundation Conditions " and Addendums 1 - 2 , Boğaziçi University, İstanbul.

Durgunoğlu, Turan, (1990), "Kınalı - Sakarya Motorway - Lot 4A Ağadere Viaduct - V5 Geotechnical Report for the Stability and Foundation Conditions", Boğaziçi University, İstanbul.

Kenney, T. C. (1967), "The Influence of Mineral Composition on the Residual Strength of Natural Soils", Proceedings, Oslo Geotechnical Conference pp.123 - 130.

Nguyen, V.V. (1984) "A technique for the Back Analysis of Slope Failures", Proceedings 4th Australia - New Zealand Conference, Geomechanics pp. 617 - 622